

Precision Low - Torque - Potentiometer F25R

Metal Housing



The Low - Torque - Potentiometer is a variable resistor with an extremely low torque.

In order to attain this torque, the contact pressure of the slider tap to the winding is kept as low as possible.

Noble metal alloys are exclusively used for the slider tap and for the winding.

All other parts of the Low - Torque - Potentiometer are made of corrosion-resistant materials.



mechanical data

- 1.1 housing..... : aluminium
- 1.2 shaft..... : stainless steel $\varnothing 1\text{mm}$
- 1.3 bearing..... : jewel bearing
- 1.4 resistor element..... : noble metal winding
- 1.5 slider tap / wiper tap..... : noble metal, double
- 1.6 housing type of protection..... : IP 60
- 1.7 connections..... : terminal wires, 200 mm
- 1.8 mounted by : clamping claws
- 1.9 mechanical rotation angle..... : $290^\circ +5^\circ$
- 1.10 electrical rotation angle..... : $290^\circ / \text{option } 270^\circ -1^\circ +2^\circ$
- 1.11 rotation speed..... : max. 1 rps
- 1.12 torque..... : 0,002 to 0,003 Ncm
- 1.13 rotation load life..... : 50×10^6 slider path (360°)

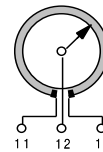
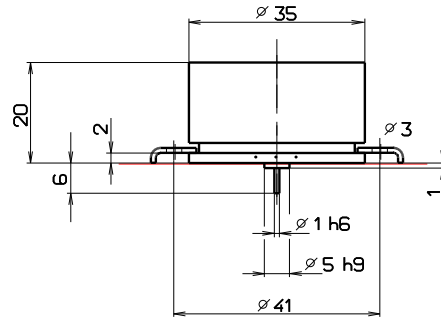

terminal plan		
point	function	colour
11	winding	red
12	slider	yellow
13	winding	blue

electrical data

- 2.1 resistance values, standard..... : according to table
- 2.2 resistance values,max possible : according to table
- 2.3 resistance tolerance..... : $\pm 3\%$
- 2.4 lowest starting resistance..... : 0,1% of overall resistance + $0,3\Omega *1$
- 2.5 linearity tolerance..... : $\pm 0,3\%$ effectively $\pm 0,7\% *2$
- 2.6 insulation resistance..... : 20 M-Ohm
- 2.7 test voltage..... : 500 V, 50 Hz
- 2.8 operating voltage..... : max. 50 V
- 2.9 power rating..... : max. 1,5 Watt
- 2.10 slider load current..... : 1 mA (max., load life)
- 2.11 temperature range..... : -50°C till $+100^\circ\text{C}$
- 2.12 temperature coefficient..... : 20 ppm/ $^\circ\text{C}$

power derating curve

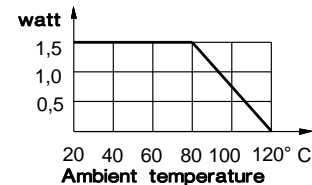

*1 The value applies only for version with short-circuit tracks and stops.

*2 incl. potential jump between winding turns

options

short-circuit tracks
centre tap
rotation angle,electrical and mechanical
resistance tolerance: $\pm 1\%$
shaft: special length, continuous
stops (rotation angle max. 350°)
suitable for oil-filled instruments
torque 0,001 Ncm
functional winding

accessories

outer housing
mounting set
couplings

other types

F25RD: multiple versions
F25RU: throughrotation
F25REB: resistance values in accordance with DIN 43822
F25RM: integrated measuring transducer 0/4...20 mA
F25R Lin.: winding linearized

F25Z160: dial surface mounting $\varnothing 160$
F25Z100: dial surface mounting $\varnothing 100$

Standard resistance values in Ohm other values available

135°	270°	290°	297°
200	30	32,2	110
1K	100	107,4	220
2K	200	215	
	500	537	
	1K	1,074K	
	2K	2,148K	
	5K	5,370K	

Sheet #: KE0101.docx

Amendment/ Print: 03.11.17 / 03.11.17

Order #:

ALTMANN Potentiometer

Herringhauser Straße 29
32051 Herford - Germany

P.O. Box 11 42
32001 Herford - Germany

Phone: 05221/3404-0
Fax : 05221/3404-29

www.potentiometer.de
eMail: info@potentiometer.de

Subject to technical
amendments Form.#: 00000000